

**IECEE**

**CB-SCHEME**

**OD-CB2015-Ed.1.3**

**OPERATIONAL & RULING DOCUMENTS**

**ASSOCIATED CB TESTING  
LABORATORIES (ACTLs) TO OPERATE  
WITH ACCEPTED CBTLs**

**OD-CB2015-Ed.1.3**

**IEC - IECEE 2009 - Copyright**

**2009-11-30**

**all rights reserved**

Except for IECEE members and mandated persons, no part of this publication may be reproduced or utilized in any form or by any means, electronic or mechanical, including photocopying and microfilm, without permission writing from the publisher

IECEE Secretariat, 3, rue de Varembé, Geneva, Switzerland, Telefax : +41 22 919 0300, e-mail : [pro@iec.ch](mailto:pro@iec.ch)



# IEC System for Conformity Testing and Certification of Electrotechnical Equipment and Components - IECEE CB Scheme

## 1. Introduction

1.1 This Operational Document applies to Associated CB Testing Laboratories (ACTLs) that carry out specific and/or selected tests as part of a complete set of Type Testing required to issue a CB Test Report.

1.2 An Associated CB Testing Laboratory participates in the IECEE CB Scheme under the responsibility of a Main CB Testing Laboratory (CBTL) and its National Certification Body (NCB) that issues a CB Test Certificate based on testing performed by the ACTL and/or the CBTL.

Note: An Associated CB Testing Laboratory does not issue the CB Test Report. Only CBTLs issue CB Test Reports.

1.3 A “Main CBTL” is a fully capable CBTL for the product categories in its accepted scope. There may be more than one “Main CBTL” within the same NCB/CBTL family.

1.4 Each NCB and CBTL that contemplates the use of an Associated CB Testing Laboratory(ies) as part of its operation must comply with the criteria and requirements contained in this OD.

## 2. General Requirements

2.1 Associated CB Testing Laboratories must comply with the requirements of ISO/IEC 17025 and all relevant Operational Documents (ODs) of the IECEE CB Scheme.

2.2 An Associated CB Testing Laboratory is a testing facility that has a limited testing capability within its recognized scope of specific Product Categories or standards, and may need to rely upon the Main CBTL, with which it is associated, to handle tests and/or products outside its limited capabilities. The status and specific scope of the ACTL shall be within the scope of the Main CBTL with which it is associated.

2.3 There are two types of Associated CB Testing Laboratories, as follows:

### a) Satellite CB Testing Laboratory

i) A laboratory that has less than the required testing capability of a fully equipped Main CBTL, i.e. equipped based on the market and customers served.

ii) A Satellite Testing Laboratory will typically possess a full or nearly full capability to perform all tests on the products that it is likely to test based on the market and customers served.

NOTE: In the context of 2.3, a), ii) related to “full or nearly full capability to perform all tests on the products that it is likely to test based on the market and customers served” means that the Satellite Testing Laboratory does not need to possess all the required equipment and capability for a particular IEC Standard; but only, that related to the actual products it is likely to test based on the market and customers served. The responsible NCB (or the Main CBTL) is responsible for knowing the equipment and capability of the SL and, therefore, should be asking the SL to only carry out testing within its capability. This means that the SL must have a full or nearly full capability based solely on the products it is requested to test except for “hardly ever used and expensive” equipment.

In such cases, missing equipment could be:

- “Expensive and hardly ever used” equipment located at the designated Specialized Facility as described in this Operational Document.
- “Expensive and hardly ever used” equipment located at the Main CBTL and which can be easily used without interrupting the testing procedure sequence.



## IEC System for Conformity Testing and Certification of Electrotechnical Equipment and Components - IECEE CB Scheme

iii) There are two options for the Satellite Testing Laboratory relationship based on the NCB-CBTL relationship.

Option 1 - NCB and CBTLs are part of the same corporate structure

SL is controlled as part of the NCB/CBTL corporate structure, as follows:

- The NCB is responsible for managing and coordinating the activities of the SL just as it is for its CBTLs.
- The NCB may appoint one of the “Main CBTLs” (Sub-clause 3.2) to be responsible for managing and controlling the SL.

Option 2 - NCB and CBTLs are not part of the same corporate structure

SL is controlled by the NCB, as follows:

- Management and coordination of the SL is through a contractual arrangement that is equivalent to the arrangement the NCB has with its CBTLs (i.e. SL could be within or outside of the NCB's corporate structure).
- The NCB is required to carry out supervisory activities (Sub-clause 3.1) to ensure the SL's operations are in compliance with the IECEE requirements.
- With the approval of the NCB, one of the NCB's “Main CBTLs” may be appointed to manage and control the SL (Sub-clause 3.2).

iv) A Satellite Testing Laboratory is permitted to work with only one CBTL of the responsible NCB.

v) A Satellite Testing Laboratory cannot be used to cover “Required” status equipment that a CBTL does not have.

Note: The Satellite Testing Laboratory concept is particularly useful for those standards that cover a large variety of product types and which have not been sub-grouped.

### b) Specialized Facility

i) A laboratory that is a dedicated testing facility conducting highly specialized testing requiring test equipment that is very expensive to procure and maintain, and might otherwise be used infrequently.

ii) A Specialized Facility can be a stand-alone facility that can be used by ALL of the CBTLs of a responsible NCB(s).

iii) A Specialized Facility is accepted by the IECEE to carry out specific types of tests that are common to a number of product standards.

iv) A Specialized Facility can be within (i.e. a part of) a fully capable CBTL that can be used by ALL of the CBTLs of a responsible NCB.v) A Specialized Facility can cover “Required” status equipment that the Main CBTL does not have provided that the concept of Specialized Facilities according to this OD is fully maintained.vi) The NCB, or its Main CBTL, must be able to demonstrate full control of the Specialized Facility.

vii) There are two options for the NCB-Specialized Facility (SF) relationship based on the NCB-CBTL relationship.

Option 1 - NCB and CBTLs are part of the same corporate structure

SF is controlled as part of the NCB/CBTL corporate structure, as follows:

- The NCB is responsible for managing and coordinating the activities of the SF just as it is for its CBTLs.
- The NCB may appoint one of the “Main CBTLs” (Sub-clause 3.2) to be responsible for managing and controlling the SF.

Option 2 - NCB and CBTLs are not part of the same corporate structure

SF is controlled by the NCB, as follows:



## IEC System for Conformity Testing and Certification of Electrotechnical Equipment and Components - IECEE CB Scheme

- Management and coordination of the SF is through a contractual arrangement that is equivalent to the arrangement the NCB has with its CBTLs (i.e. SF could be within or outside of the NCB's corporate structure).
- The NCB is required to carry out supervisory activities (Sub-clause 3.1) to ensure the SF's operations are in compliance with the IECEE requirements
- With the approval of the NCB, one of the NCB's "Main CBTLs" may be appointed to manage and control the SF (Sub-clause 3.2).

vii) A Specialized Facility may also support other CBTLs and their associated Satellite Testing Laboratories working with the same NCB.

viii) A Specialized Facility can cover a test or a sequence of tests as part of an overall testing program, providing there is no disruption to the test sequence as required by the standard.

Note 1: A Specialized Facility might be expected to have the following types of testing equipment:

- Extra-large environmental testing chambers
- Electromagnetic testing facilities and equipment
- IP testing equipment
- Mechanical testing equipment (i.e. vibration, extensive impact)
- Corrosion testing equipment
- X-Radiation, microwave and Ultraviolet (UV) measuring equipment
- Ultrasonic and sound pressure level measuring equipment
- Laser measuring equipment
- High capacity short-circuit testing equipment
- Resistance to heat and fire testing equipment
- Thermoplastics testing equipment (i.e. short-term property evaluations, long-term property evaluations, polymeric materials used in electrical equipment evaluations, industrial laminates, vulcanized fiber, materials used for printed wiring boards, filament wound tubing, flexible dielectric film materials, flammability, tracking, hot-wire ignition)
- High-vacuum devices testing equipment (e.g. IEC 60065)

Note 2: Any testing sequences that cannot be separated, such as humidity testing followed by dielectric testing, must be carried out as a suite of tests as required by the standard.

Note 3: Note 2 does not suggest that humidity testing facilities may be completely omitted from the Main CBTL.

Note 4: Where a Main CBTL does not possess some major, expensive, specialized and required ("R") test equipment that is available at the Specialized Facility used by this Main CBTL, this relationship is not considered subcontracting.

2.4 The qualification criteria for an Associated CB Testing Laboratory are the same as applicable to a CBTL, but are applied as appropriate to its limited scope and capabilities. Well-functioning quality management systems and continuous exchange of information between the Main CBTL and its Associated CB Testing Laboratory are the necessary pre-requisites for acceptance.

2.5 The geographic location of the Associated CB Testing Laboratory in relation to the location of the Main CBTL must permit an effective completion of the required full test program for the products within the scope of these laboratories. Specifically, the shipment of test samples between the testing facilities must not present undue difficulties for routine test programs.

Note: This applies particularly to Specialized Facilities.



# IEC System for Conformity Testing and Certification of Electrotechnical Equipment and Components - IECEE CB Scheme

The location of Associated CB Testing Laboratory must also permit its assessment and re-assessment at the same time as and in conjunction with the assessment or re-assessment of the Main CBTL.

2.6 The technical competence to carry out testing activities is checked against ISO/IEC 17025 and the relevant IEC Standards, or parts thereof, for which the Associated Testing Laboratory is seeking acceptance.

## 3. Responsibilities

### 3.1 Responsibilities of the NCB

- Over-viewing operations of its Associated CB Testing Laboratory(ies) on an ongoing basis in cooperation with its Main CBTL(s).
- Over-viewing required training of its Associated CB Testing Laboratories on an ongoing basis in cooperation with its Main CBTL(s).
- Auditing (initially and once per year thereafter) each Main CBTL and each Associated CB Testing Laboratory in accordance with ISO/IEC 17025, including technical scope and quality management system.

Note: According to ISO/IEC Guide 65, Sub-clause 4.7 (Internal audits and management reviews)

- Ensuring that the Associated CB Testing Laboratory(ies) participate(s) in CTL Proficiency Testing Program as applicable to its limited scope.
- Ensuring that the Main CBTL is in full control of its Associated CB Testing Laboratory(ies) and that it does not lose its technical capability over time. This shall be confirmed and documented during the NCB's audits of the Main CBTL's and the Associated CB Testing Laboratory's operations.

### 3.2 Responsibilities of the Main CBTL

- Training the Associated CB Testing Laboratory(ies) for which it is responsible as appointed by the Responsible NCB on an ongoing basis in the operation and procedures of the IECEE Scheme.
- Establishing the technical competence of the laboratory.
- Participating in the NCB's audits or auditing (on NCB's behalf) of the Associated CB Testing Laboratory(ies) for which the Main CBTL is responsible.
- Carrying out a review of test reports and/or partial test reports prepared by the Associated CB Testing Laboratory(ies) for which it is responsible.
- Arranging all other required tests that are not performed at the Associated CB Testing Laboratory(ies).
- Compiling and issuing the CB Test Report based on the tests conducted by its Associated CB Testing Laboratory(ies) and its own tests.
- Coordinating participation of its Associated CB Testing Laboratory(ies) with its own CTL Proficiency Testing Programs (as applicable to the Main CBTL's scope and that of the ACTL).
- Issue the CB Test Report; however, each testing location must be identified along with the tests carried out at each location.

### 3.3 Responsibilities of the Associated CB Testing Laboratory

- Operating in compliance with the requirements of ISO/IEC 17025 and the IECEE Rules of Procedure, IECEE 02.
- Appointing an appropriate person to be responsible for the facilities and/or services provided to the Main CBTL and its Responsible NCB.



## **IEC System for Conformity Testing and Certification of Electrotechnical Equipment and Components - IECEE CB Scheme**

- Ensuring that all tests are carried out and reported to the Main CBTL in accordance with the applicable technical requirements and the instructions of the Main CBTL.
- Participating in applicable CTL Proficiency Testing Programs according to its limited scope.

Note: An Associated CB Testing Laboratory does not issue CB Test Reports; however, each testing location must be identified along with the tests carried out at each location.

### **4.0 Conditions Concerning Affiliation with the Main CBTL**

4.1 A Satellite Testing Laboratory as described in Sub-clause 2.3 a) shall operate in the IECEE CB Scheme with only one Main CBTL and one NCB in a specific product category.

4.2 A Specialized Facility as described in Sub-clause 2.3 b) shall be permitted to participate in the IECEE Scheme with more than one CBTL associated with one NCB. A Specialized Facility shall not be permitted to participate in the CB Scheme for more than one NCB.

#### **4.3 Qualification of an Associated CB Testing Laboratory**

4.3.1 The NCB shall initiate the evaluation of the ACTL and the Main CBTL arrangement and competence, which typically should include the following steps:

4.3.2 Initial evaluation of the Quality System and Procedures employed by both the Main CBTL and the ACTL.

4.3.3 Initial evaluation of the general competence of the ACTL in testing for conformity assessment.

4.3.4 Review and endorsement of any previous recommendation by the Main CBTL for the competence of the ACTL staff to perform tests within the specified limited scope.

4.3.5 Any additional training of technical staff at the Main CBTL and the ACTL as determined by the NCB's assessment.

### **5.0 Assessment by the IECEE**

5.1 Associated CB Testing Laboratories are subject to the same assessment and acceptance procedure as CBTLs.

5.2 A formal initial assessment of the candidate Associated CB Testing Laboratory and a "partial" assessment, as appropriate, of the Main CBTL shall be carried out by the IECEE Assessment Team in accordance with IECEE 02 Sub-clause 5.3 and the applicable Operational Documents.

5.2.1 All parties responsible for managing, controlling and coordinating the activities of the ACTL shall be assessed to the necessary extent during the process of assessing the ACTL.

5.3 The initial assessment of an Associated CB Testing Laboratory can be carried out on a "stand-alone" basis without a "partial" assessment of the Main CBTL when the Main CBTL has been previously assessed or reassessed within the 3-year reassessment cycle and accepted to operate in a determined Scope [product category(ies)] through an on-site assessment carried out earlier. The relevant procedures implemented by the Main CBTL for the oversight and control of the Associated CB Testing Laboratory (Satellite CB Testing Laboratory or Specialized Facility) shall be available for review and acceptance by the Assessment Team.



## **IEC System for Conformity Testing and Certification of Electrotechnical Equipment and Components - IECEE CB Scheme**

5.4 Any further assessment (re-assessment, scope extension, etc.) of the Associated CB Testing Laboratory that is related to the Scope of both the responsible Main CBTL and the Associated CB Testing Laboratory, regardless of the distance between them and their location, will take place at the same time as and in conjunction with the assessment or reassessment of the responsible Main CBTL.

5.5 Assessment Time Frame, Size and Composition of the Assessment Team

- a) For a Satellite Testing Laboratory, the time frame, size and composition of the Assessment Team will follow the guidelines as used for assessment of CBTLs.
- b) Specialised Laboratories are, by definition, special. Therefore, the assessment team expertise is critically important and is currently verified by the IECEE Secretariat during the selection of the Technical Assessor(s). Once the expertise properly covers the scope of the Specialized Laboratory, the assessment team can determine the timeframe of the assessment. That "model" is then recorded in the IECEE Secretariat database to make sure that next time with another applicant body, there will be "equal treatment" and transparency.

5.6 Upon successful completion of the IECEE Peer Assessment, an ACTL is registered as an accepted Satellite CB Testing Laboratory or an accepted Specialized Facility for the relevant limited scope, under the responsibility of its NCB.

5.7 An ACTL is subject to the same application and assessment fees as the Main CBTL.

### **6.0 Supervision of an Associated Laboratory's Operations**

6.1 The involvement of the Main CBTL in the ACTL operations, as directed by the responsible NCB, is essential for the credibility of the ACTL Procedure as described in this Operational Document.

6.2 The NCB and/or the Main CBTL shall maintain adequate technical overview of all testing work carried out by the ACTL, including training, periodic audits, comparison testing, examination of test samples, and ongoing review of test reports.

### **7.0 CB Test Reports**

7.1 Test reports are compiled and issued by the Main CBTL. Where an ACTL carries out a full testing program and prepares a draft CBTR for review by the Main CBTL, the CB Test Report shall carry the signatures of the ACTL and of the issuing CBTL.

7.2 The CB Test Report shall contain information regarding which tests were conducted at the ACTL(s) and which at the Main CBTL (if any). This information shall be added to the "Summary of testing" or "General product information" area of the CB Test Report.

**ANNEX 1**

**Associated CB Testing Laboratories  
Satellite Laboratories and Specialized Facilities  
Within the Structure of the IECEE CB Scheme**

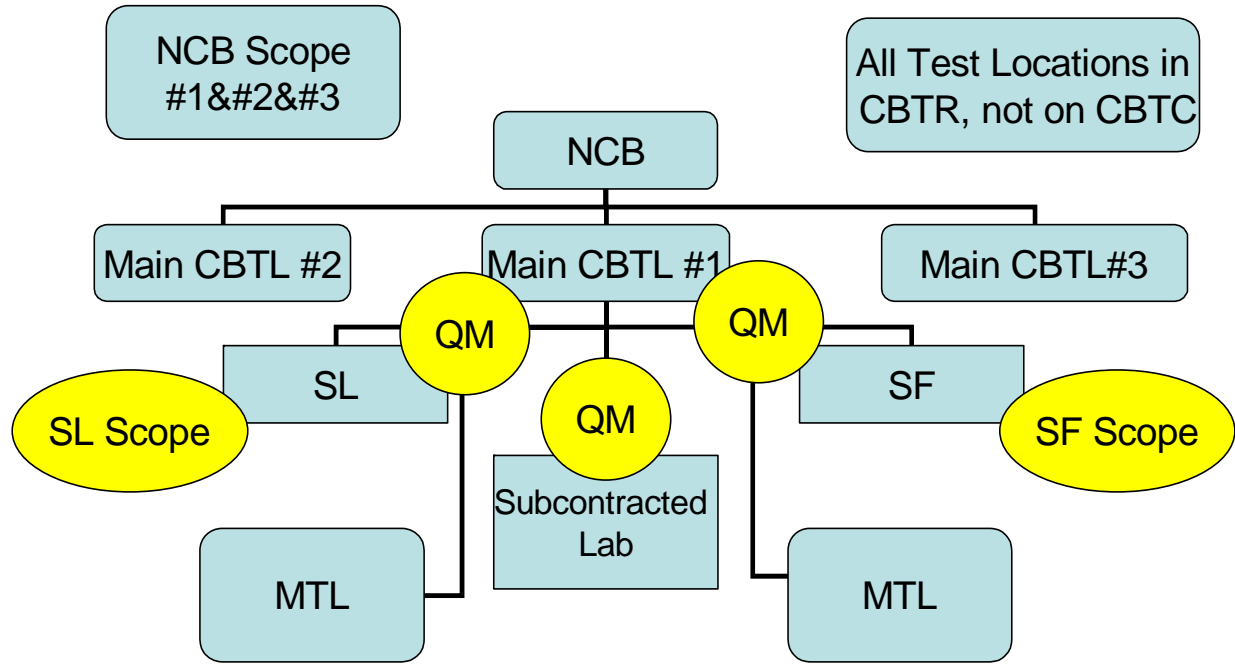

## ANNEX 2

### Use of Specialized Facilities as Compared to Subcontracting

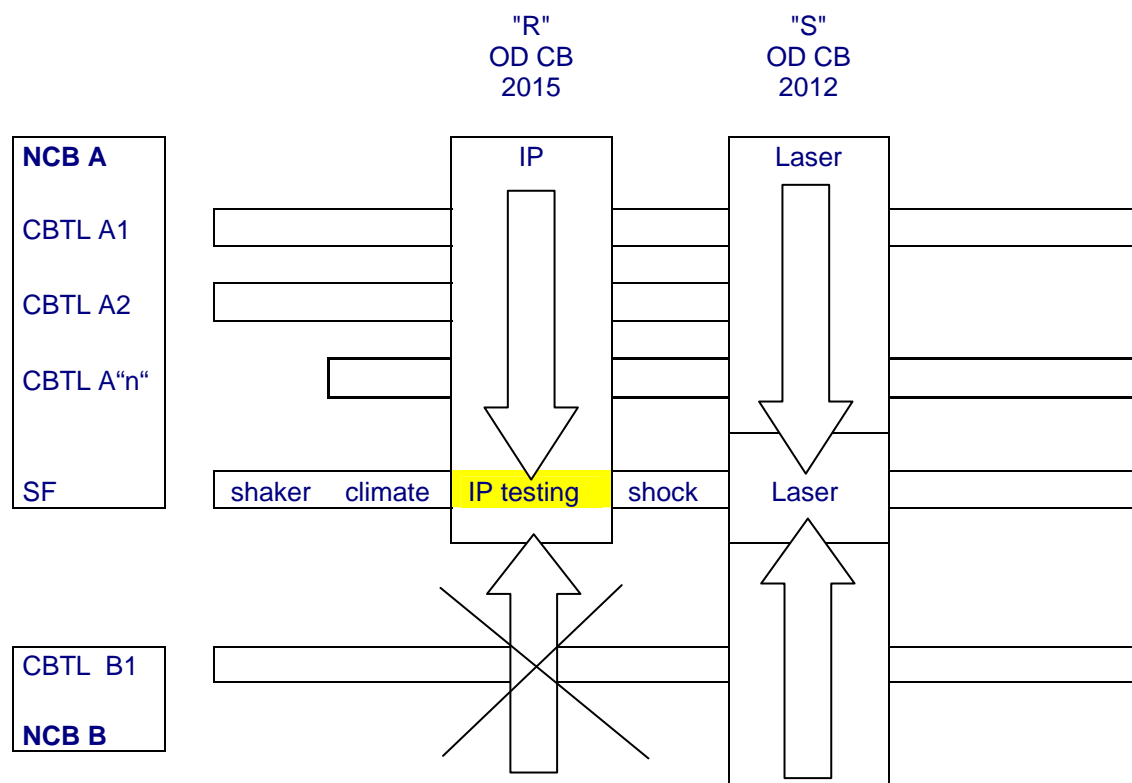

The diagram in Annex 2 is intended to demonstrate the difference between subcontracting according OD-CB2012 and Associated Laboratories according OD-CB2015. It refers to two independent groups of NCB/CBTL combinations that are not linked at a corporate level.

The upper part of the diagram shows an NCB A with its associated CBTLs A1 to A'n'. The lower part of the diagram shows a different NCB B with an associated CBTL B1.

The horizontal boxes indicate the respective scopes of the CBTLs.

The Specialized Facility, SF, is associated with NCB A as the only possible relationship according to OD-CB2015. The SF carries out the specialized tests for the "n" CBTLs of NCB A, indicated by the arrow pointing to IP testing.

The same IP testing cannot be accepted by the SF from CBTL B.

However, with subcontracting permitted according to OD-CB2012, the laboratory (acting as SF for NCB A and its associated CBTLs) may accept subcontracting from CBTL B (e.g. laser in category OFF).

**ANNEX 3  
Possible NCB, CBTL, SL and SF Relationships**

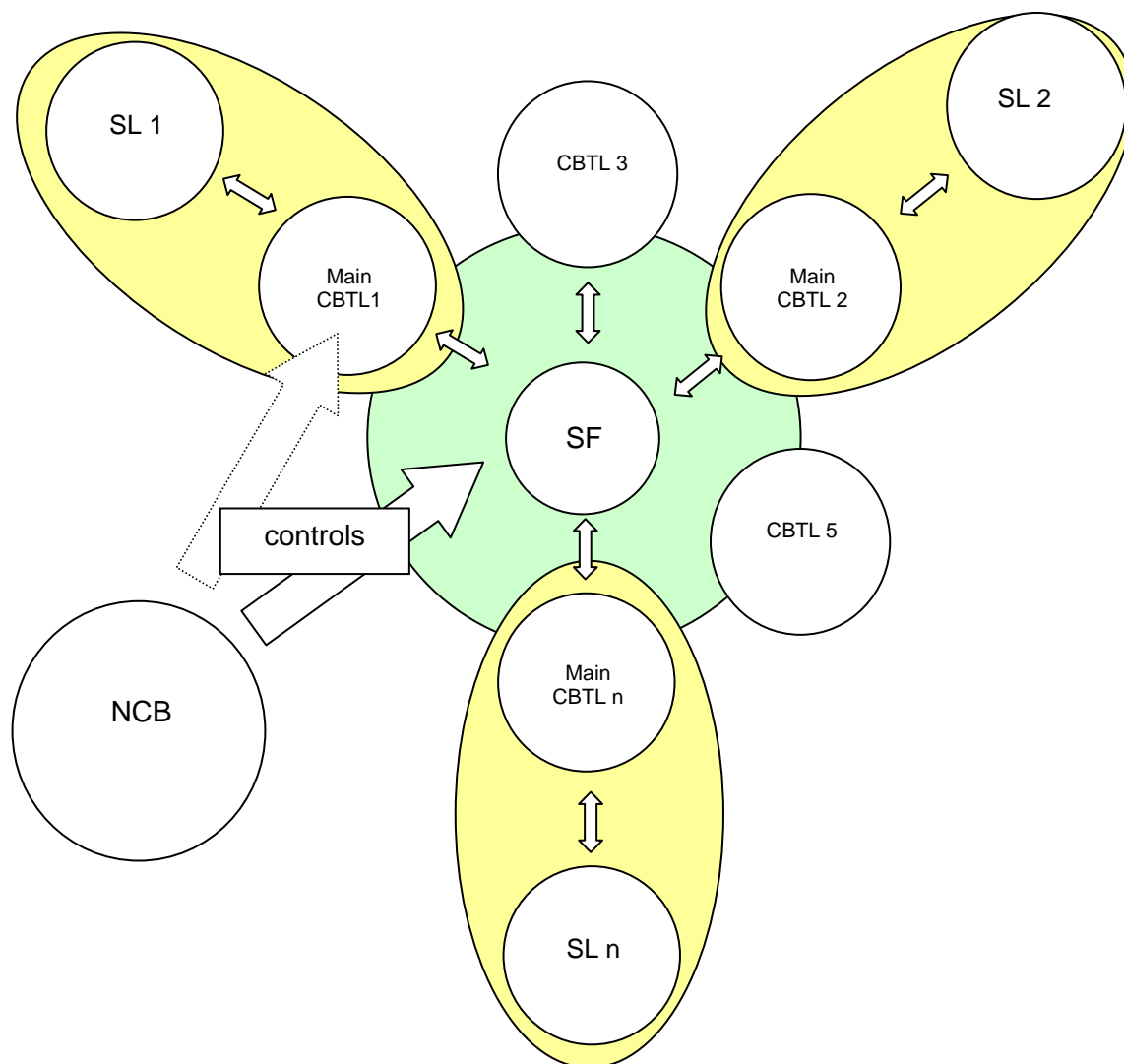

The diagram in Annex 3 is intended to show one NCB operating with several CBTLs. Some of the CBTLs have Satellite Laboratories (SLs) only, e.g. SL 1 only works with CBTL1 but not with CBTL 2. The Specialized Facility (SF) is allowed to work with all CBTLs under the control of the NCB. The NCB has control and responsibility over the SF, and may, however, delegate this task to one appointed CBTL (e.g. CBTL 1), which then acts as the Main CBTL, e.g. being assessed together with the SF at the same time. CBTL 3 does not have a satellite laboratory, but a connection to the SF, while CBTL 5 does not have a satellite laboratory and does not use the SF.

## ANNEX 4

### Example of CBTL, SF and SL Test Services and the Responsible NCB

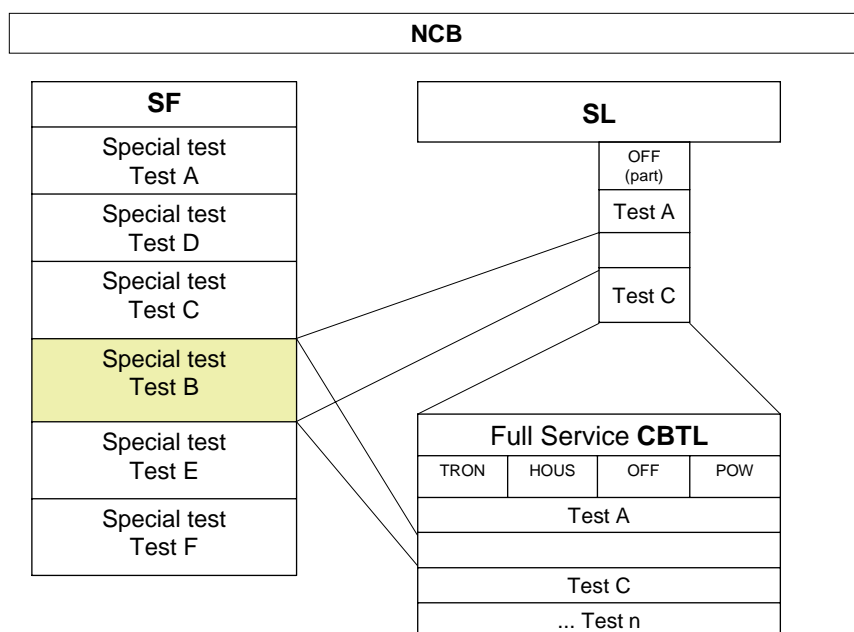

The diagram in Annex 4 shows an NCB under a common corporate umbrella with three entities all within the scope of OD-CB2015, as follows:

- A full-service CBTL with the accepted product categories of TRON, HOUS, OFF and POW. This full-service CBTL is able to perform all the necessary tests required by the relevant standards as indicated from Test A to Test n. These tests might be “generic” like temperature rise or specialized to a certain product category.
- A satellite laboratory to the CBTL above. It has only capability for a part of category OFF (e.g. just power supplies) and can as such cannot become a CBTL and therefore acts as Satellite Laboratory under the CBTL having the full scope of OFF.
- The Specialized Facility (SF) has in this example the capability for five types of tests, indicated as Test A to Test F. Test B could e.g. “environmental simulation and testing” which includes any type of climatic chambers, IP testing (water and dust).

Both laboratories – the CBTL and the associated Satellite Laboratory – have to consider the investment into this required (“R”) type of test, maintain the equipment and the capability to operate it. It is the economic decision of the company under which the NCB and these laboratories operate, to concentrate this type of test into the “Specialized Facility” according to OD-CB2015. According to the above diagram both labs – the CBTL and the Satellite Laboratory – are handing over the Test B to be performed in the Specialized Facility.

Note: The Diagrams in Annexes 2, 3 and 4 were prepared by Dr. Wolfgang Kreinberg, Member of WG 16.